

Charlotte[®]

air



AIR STAPLE/NAIL GUN

MODEL NO: CSN-1D

PART NO: 3110387

OPERATION & MAINTENANCE INSTRUCTIONS

UK
PA | CE

ORIGINAL INSTRUCTIONS

DL1122 - REV 2

INTRODUCTION

Thank you for purchasing this CLARKE product.

Before attempting to use this product, please read this manual thoroughly and follow the instructions carefully. In doing so you will ensure the safety of yourself and that of others around you, and you can look forward to your purchase giving you long and satisfactory service.

GUARANTEE

This product is guaranteed against faulty manufacture for a period of 12 months from the date of purchase. Please keep your receipt which will be required as proof of purchase.

This guarantee is invalid if the product is found to have been abused or tampered with in any way, or not used for the purpose for which it was intended.

Faulty goods should be returned to their place of purchase, no product can be returned to us without prior permission.

This guarantee does not effect your statutory rights.

CONSUMABLES

The following Consumables are available from your local Clarke Dealer

NAILS - 1.25MM CROWN (18 GAUGE)		STAPLES - 5.5MM CROWN	
Length	Part No:	Length	Part No:
20mm	1800415	16mm	1800429
30mm	1800417	19mm	1800431
35mm	1800421	25mm	1800435
40mm	1800423	32mm	1800436
50mm	1800427	40mm	1800437

SAFETY WARNINGS

SAFETY OF THE STAPLE/NAIL GUN

1. Check prior to use that the safety and triggering mechanism is functioning properly and that all nuts and bolts are tight.
2. Do not carry out any modifications to the staple/nail gun.
3. Do not disassemble or make inoperative any parts of the staple/nail gun such as the safety yoke.
4. Do not perform any "emergency repairs".
5. The staple/nail gun should be serviced properly and at regular intervals in accordance with the instructions.
6. Avoid weakening or damaging the staple/nail gun, for example by:
 - punching or engraving;
 - modification not authorised by the manufacturer;
 - guiding against templates made of hard material such as steel;
 - dropping or pushing across the floor;
 - using the equipment as a hammer;
 - applying excessive force of any kind.

SAFETY AT WORK

1. Never point any operational staple/nail gun at yourself, any other person or animals.
2. Hold the staple/nail gun during the work operation in such a way that no injuries can be caused to the head or to the body in the event of a possible recoil.
3. Never actuate the staple/nail gun into free space. This will avoid any hazard caused by free flying fasteners and excessive strain on the tool.
4. The staple/nail gun shall be disconnected from the compressed air system during transportation, especially where an unusual physical posture is adopted whilst moving.
5. Carry the staple/nail gun at the workplace using only the handle, and never with the trigger actuated.
6. Take conditions at the workplace into account. Fasteners can penetrate thin workpieces or slip off corners and edges of workpieces, and thus put people at risk.
7. For personal safety, use protective equipment such as hearing and eye protection and safety gloves.

SAFETY SYMBOLS

	Read manual before use		Wear ear defenders
	Wear suitable eye protection		Do not use on scaffolding or ladders
	May only be used with an effective safety yoke		

PREPARING THE STAPLE/NAIL GUN FOR USE



CAUTION: READ AND OBSERVE THESE OPERATING INSTRUCTION BEFORE USING THE STAPLE/NAIL GUN.

CONNECTION TO THE COMPRESSED AIR SYSTEM



WARNING: ENSURE THE AIR SUPPLY IS CLEAN AND DOES NOT EXCEED 100PSI WHILE OPERATING THE NAIL/STAPLE GUN.

1. Ensure that the pressure supplied by the compressed air system does not exceed the maximum allowable pressure of the staple/nail gun See "Specification" on page 8.
2. Make sure that the safety yoke is not depressed.
3. Connect the staple/nail gun to the compressed air supply using suitable hose equipped with quick-action connectors.
4. Check for proper functioning by applying the muzzle of the staple/nail gun to a piece of wood and actuating the trigger once or twice.

RECOMMENDED CONNECTION CONFIGURATION

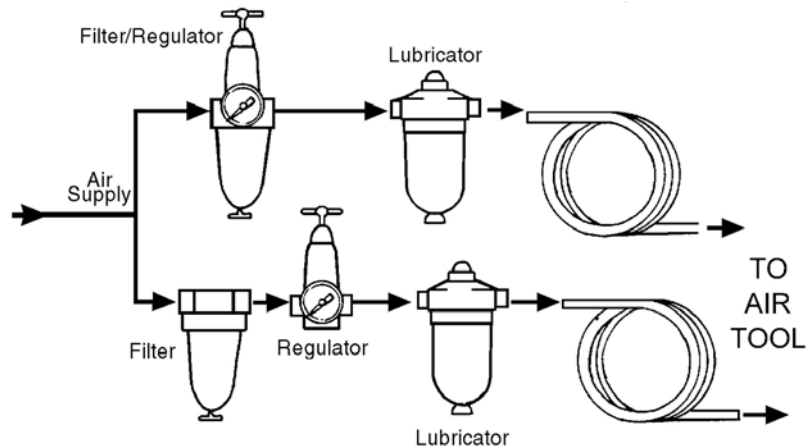

TIPS

- Drain the compressor air tank daily. Water in the air line will damage the nail/staple gun and will invalidate your warranty.
- Clean air inlet filter on the staple/nail gun weekly.
- Line pressure should be increased to compensate for unusually long air hoses (over 8m). The minimum hose diameter should be 1/4" I.D. and fittings must have the same bore.
- Keep hose away from heat, oil and sharp edges. Check hoses for wear, and make certain that all connections are secure.

FILLING THE MAGAZINE

- Only those fasteners specified in "Consumables" on page 2 may be used.
 - When filling the magazine, hold the staple/nail gun so that the muzzle is not pointing towards yourself or any other person.
1. With your fingers well away from the trigger, and the tool pointed away from you, and anyone in the vicinity, press and hold the magazine catch.
 2. Pull out the magazine and load with appropriate nails or staples as shown.

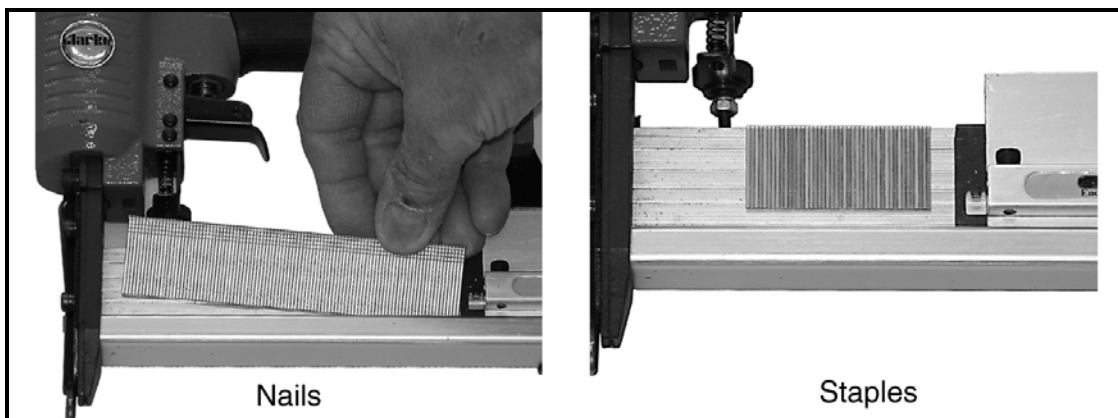

HANDLING THE STAPLE/NAIL GUN

1. Pay attention to the SAFETY WARNINGS in these operating instructions.
2. Set the operating pressure to between 60-100psi, depending upon the size of nail used and type of material being worked.
3. Having checked that the staple/nail gun is functioning correctly, press the staple/nail gun against the work piece at a right angle and pull the trigger.
4. Check whether the fastener has been driven into the workpiece.
 - If it is protruding, increase the air pressure by 0.5 bar.
 - If it has been driven in too far, reduce the air pressure by 0.5 bar.
 - Check the result after each adjustment.
5. You should work with the lowest possible air pressure.
6. In the event of long breaks in work or at the end of the working shift, disconnect the staple/nail gun from the compressed air supply and empty the magazine.

TO CLEAR A JAM

Should a blockage occur:

1. Turn off the compressed air supply.
2. Pull the trigger to ensure the staple/nail gun is not under pressure.
3. Open the magazine and pull out the offending staple/nail.
4. Close the magazine.
5. Ensure that all parts of the nail/staple gun are secure and correctly positioned, then reconnect the air supply.

TIPS

- Do not trigger the staple/nail gun unnecessarily if the magazine is empty.
- Any defective or improperly functioning staple/nail gun must immediately be disconnected from the compressed air supply and passed to a specialist for inspection.
- Connectors and hoses should be protected against contamination from dust, debris, sand etc. which will result in leaks and damage to the staple/nail gun and the couplings.

MAINTENANCE



WARNING: DISCONNECT THE STAPLE/NAIL GUN FROM THE COMPRESSED AIR SUPPLY AND EMPTY THE MAGAZINE BEFORE PREFORMING ANY MAINTENANCE.

DAILY BEFORE USE

1. Drain water from compressor air tank and air line.
2. Check and clean, if necessary, the air inlet gauze filter.

DURING USE

1. To lubricate the internal components during operation, an air line lubricator should be used.
2. If an air system oiler is not being used, lubricate the staple/nail gun every 2 hours with a few drops of air line oil, dripped into the air inlet.
 - Clarke Air Line Oil is available from your CLARKE dealer part no. 3050825.

WEEKLY

1. Check the security of the bolts and tighten if necessary.
2. Clean air inlet filter on the staple/nail gun.

STORAGE

1. Clean the nail/staple gun after use.
2. When not in use, disconnect from air supply, clean the staple/nail gun and store in a safe, dry, childproof location.

MAINTENANCE NOTES

- Be aware that factors other than the tool may effect its operation and efficiency such as reduced compressor output, excessive drain on the airline, moisture or restrictions in the line, or the use of connectors of improper size or poor condition which will reduce air supply.
- Grit or gum deposits in the tool may also reduce efficiency. This condition can be corrected by cleaning the air strainer and flushing out the tool with gum solvent oil, or failing this, the tool should be disassembled, thoroughly cleaned, dried and reassembled.
- If the tool runs erratically or becomes inefficient, and the air supply is sound, dismantle the piston assembly and replace worn or damaged parts, or take the tool to your CLARKE dealer.
- The use of parts other than CLARKE replacement parts may result in safety hazards, decreased tool performance and will invalidate your warranty.

SPECIFICATION

Type of Tool	CSN-1D
Dimensions	255 x 54 x 252 mm
Weight (Including supplied accessories / fixings)	2.24 kg
Activation Mode	Single sequential
Drive Speed	90 (shots/min)
Compressed Air	
Maximum Allowable Pressure	120 psi /8.3 bar
Recommended Allowable Pressure Range	60 - 100 psi /4.14 - 6.9 bar
Noise Characteristic Values In Accordance With EN12549.	
Sound Pressure:	88.7 dB(A)
Sound Power Measured LwA	101.7 dBLwA
Vibration Characteristic Values In Accordance With ISO 8662-1 1: 1999	<2.5 m/s ²

DECLARATION OF CONFORMITY



Hemnal Street, Epping, Essex CM16 4LG

DECLARATION OF CONFORMITY

This is an important document and should be retained.

We hereby declare that this product(s) complies with the following statutory requirement(s):

Supply of Machinery (Safety) Regulations 2008

The following standards have been applied to the product(s):

EN ISO 11148-13:2018.

The technical documentation required to demonstrate that the product(s) meet(s) the requirement(s) of the aforementioned legislation has been compiled and is available for inspection by the relevant enforcement authorities.

The UKCA mark was first applied in: 2022

Product Description: 2 in 1 Air Staple and Nail Gun Kit
Model number(s): CSN1D
Serial / batch Number: N/A
Date of Issue: 06/10/2022

Signed:

J.A. Clarke
Director



Fitzwilliam Hall, Fitzwilliam Place, Dublin 2

DECLARATION OF CONFORMITY

This is an important document and should be retained.

We hereby declare that this product(s) complies with the following directive(s):

2006/42/EC *Machinery Directive*

The following standards have been applied to the product(s):

EN ISO 11148-13:2018.

The technical documentation required to demonstrate that the product(s) meet(s) the requirement(s) of the aforementioned directive(s) has been compiled and is available for inspection by the relevant enforcement authorities.

The CE mark was first applied in: 2011

Product Description: 2 in 1 Air Staple and Nail Gun Kit
Model number(s): CSN1D
Serial / batch Number: N/A
Date of Issue: 06/10/2022

Signed:

J.A. Clarke
Director

EXPLODED DIAGRAM

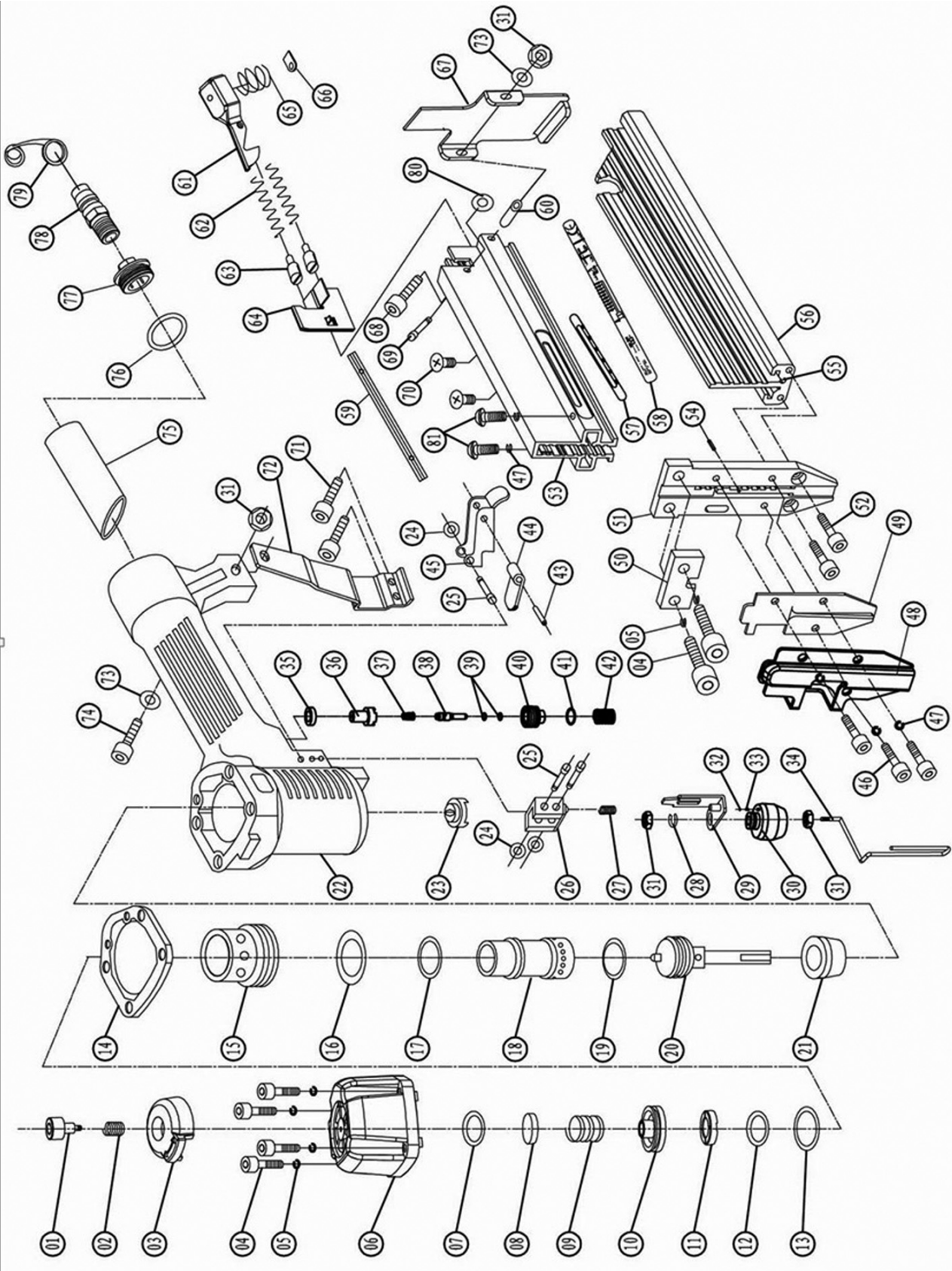

SPARE PARTS LIST

No	Description	Part No	No	Description	Part No
01	Hex. Skt Head Screw	HTCSN1D01	42	Compression Spring	HTCSN1D42
02	Compression Spring	HTCSN1D02	43	Roll Pin 2.5x16	HTCSN1D43
03	Air Deflector	HTCSN1D03	44	Safety Plate	HTCSN1D44
04	Cap Screw M5x20	HTCSN1D04	45	Trigger	HTCSN1D45
05	Lock Washer 5mm	HTCSN1D05	46	Cap Screw M4x10	HTCSN1D46
06	Cylinder Cover	HTCSN1D06	47	Lock Washer	HTCSN1D47
07	O-Ring 13.7x2.4	HTCSN1D07	48	Nose Cover	HTCSN1D48
08	Sealing Washer	HTCSN1D08	49	Drive Guider	HTCSN1D49
09	Compression Spring	HTCSN1D09	50	Spacer	HTCSN1D50
10	Head Valve	HTCSN1D10	51	Nose	HTCSN1D51
11	Sealing Washer	HTCSN1D11	52	Cap Screw M4x14	HTCSN1D52
12	O-Ring 31.2x2.5	HTCSN1D12	53	Bar	HTCSN1D53
13	O-Ring 24.8x3.5	HTCSN1D13	54	Roll Pin 1.5x10	HTCSN1D54
14	Sealing Gasket	HTCSN1D14	55	Insert	HTCSN1D55
15	Collar	HTCSN1D15	56	Magazine	HTCSN1D56
16	O-Ring 41.7x3	HTCSN1D16	57	Scale	HTCSN1D57
17	O-Ring 26.2x2.4	HTCSN1D17	58	Magazine Label	HTCSN1D58
18	Cylinder	HTCSN1D18	59	Inlay Slice	HTCSN1D59
19	O-Ring 21x3	HTCSN1D19	60	Tube	HTCSN1D60
20	Piston Assembly	HTCSN1D20	61	Catch Lever	HTCSN1D61
21	Bumper	HTCSN1D21	62	Compression Spring	HTCSN1D62
22	Gun Body	HTCSN1D22	63	Pusher Pipe	HTCSN1D63
23	Rubber Washer	HTCSN1D23	64	Pusher	HTCSN1D64
24	O-Ring 1.7x2	HTCSN1D24	65	Compression Spring	HTCSN1D65
25	Pin	HTCSN1D25	66	Washer	HTCSN1D66
26	Safety Seat	HTCSN1D26	67	Fixed Seat	HTCSN1D67
27	Compression Spring	HTCSN1D27	68	Cap Screw M4x38	HTCSN1D68
28	E-Clip 6mm	HTCSN1D28	69	Pin	HTCSN1D69
29	TUV Drive Stand	HTCSN1D29	70	Flat Head Screw	HTCSN1D70
30	TUV Adjusting Nut	HTCSN1D30	71	Cap Screw M4x6	HTCSN1D71
31	Hex Nut M4	HTCSN1D31	72	Support Seat	HTCSN1D72
32	Compression Spring	HTCSN1D32	73	Washer	HTCSN1D73
33	Steel Ball 2mm	HTCSN1D33	74	Cap Screw M4x20	HTCSN1D74
34	Safety Yoke	HTCSN1D34	75	Rubber Handle Grip	HTCSN1D75
35	Rectangle Washer	HTCSN1D35	76	O-Ring 36.3x3.55	HTCSN1D76
36	Piston Valve	HTCSN1D36	77	End Cap	HTCSN1D77
37	Compression Spring	HTCSN1D37	78	Air Plug	HTCSN1D78
38	Valve Stem	HTCSN1D38	79	Air Plug Cover	HTCSN1D79
39	O-Ring 2.5x1.5	HTCSN1D39	80	O-Ring 2.4x1.6	HTCSN1D80
40	Trigger Valve Guide	HTCSN1D40	81	Cap Screw M4x14	HTCSN1D81
41	O-Ring 11.2x2	HTCSN1D41			

A SELECTION FROM THE VAST RANGE OF

Clarke®

QUALITY PRODUCTS



AIR COMPRESSORS
From DIY to industrial, Plus air tools, spray guns and accessories.

GENERATORS
Prime duty or emergency standby for business, home and leisure.

POWER WASHERS
Hot and cold, electric and engine driven - we have what you need

WELDERS
Mig, Arc, Tig and Spot. From DIY to auto/industrial.

METALWORKING
Drills, grinders and saws for DIY and professional use.

WOODWORKING
Saws, sanders, lathes, mortisers and dust extraction.

HYDRAULICS
Cranes, body repair kits, transmission jacks for all types of workshop use.

WATER PUMPS
Submersible, electric and engine driven for DIY, agriculture and industry.

POWERTOOLS
Angle grinders, cordless drill sets, saws and sanders.

STARTERS/CHARGERS
All sizes for car and commercial use.



PARTS & SERVICE: 0208 988 7400

Parts Enquiries
Parts@clarkeinternational.com

Servicing & Technical Enquiries
Service@clarkeinternational.com

SALES: UK 01992 565333 or Export 00 44 (0)1992 565335

Clarke INTERNATIONAL Hemnall Street, Epping, Essex CM16 4LG
www.clarkeinternational.com